

DP Series

PISTON DIVERTER VALVES

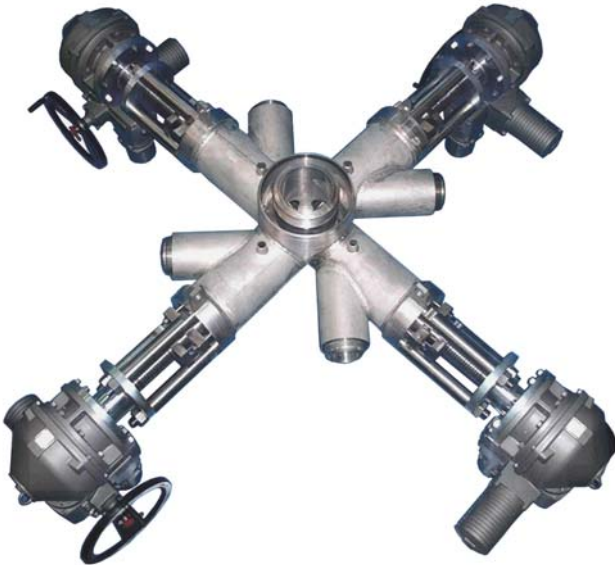

STRAHMAN DEAD SPACE FREE DIVERTER VALVES

Piston Diverter Valves

Code: **DPS4**

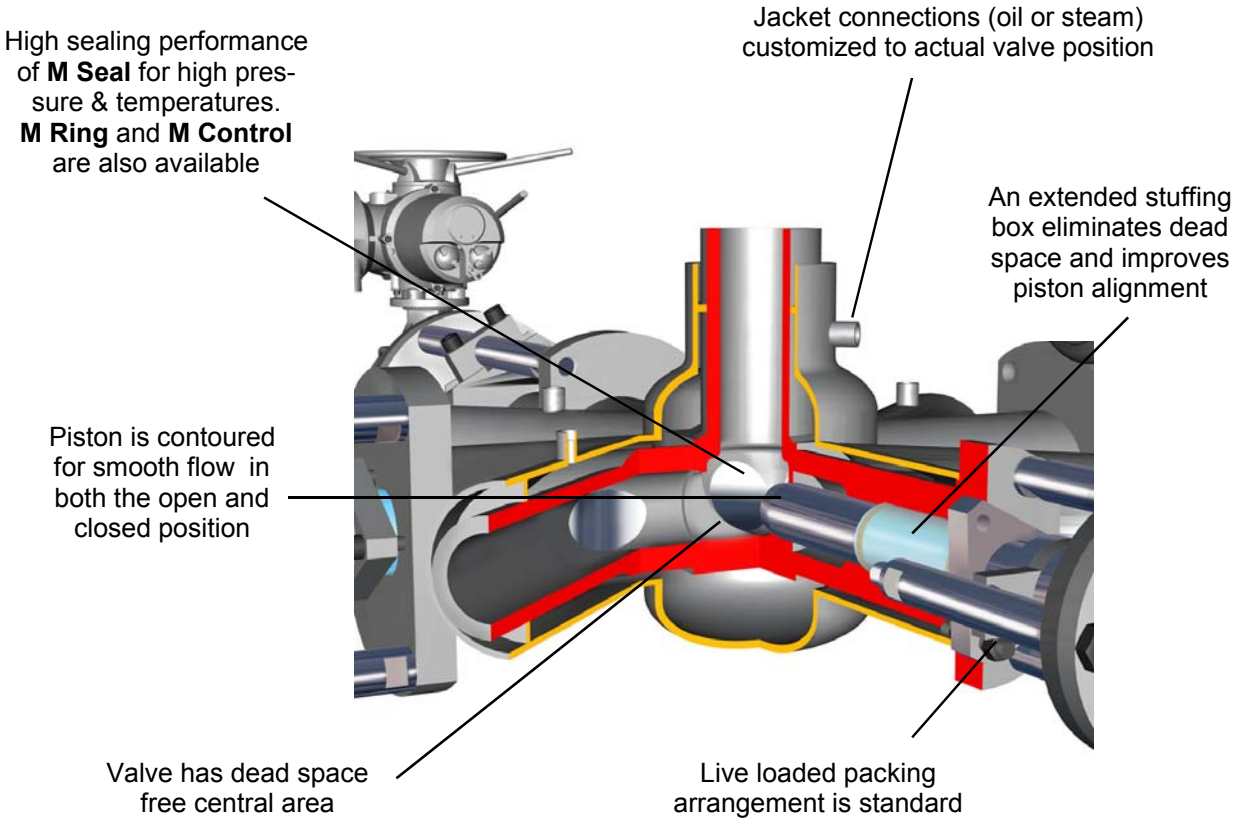
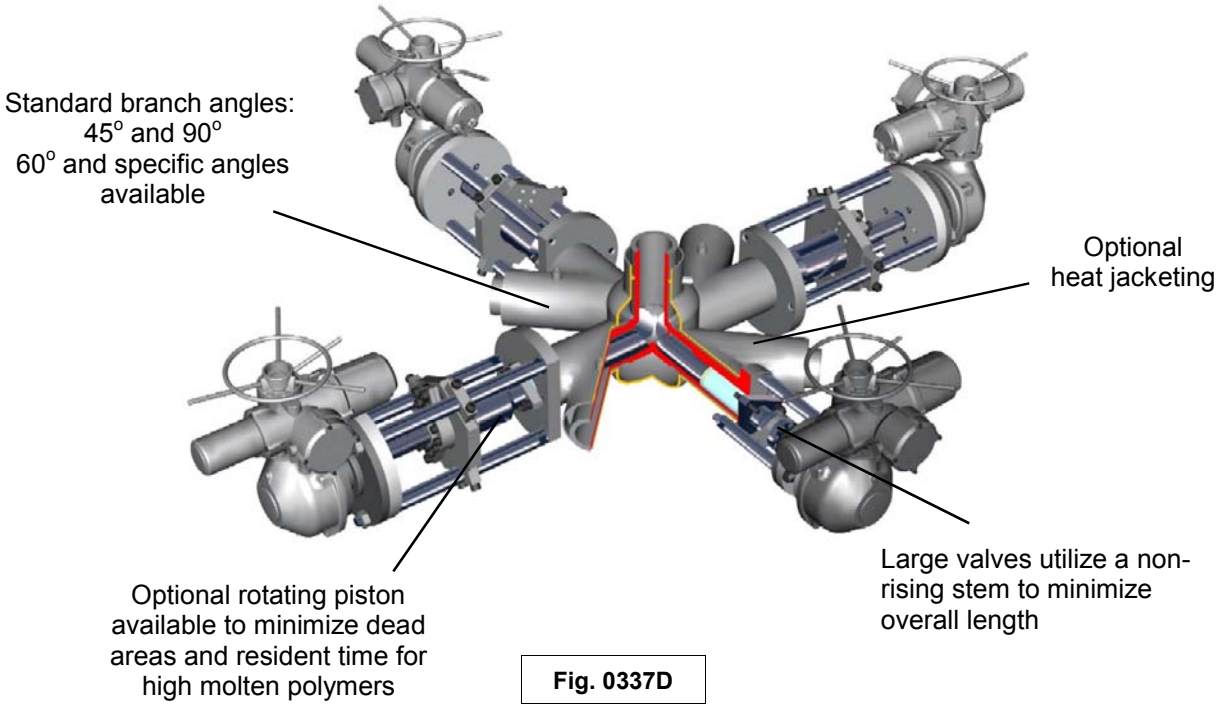

In virtually every process there is a need to divert flow. Dead space free valves are mandatory when diverting the flow of high viscosity products like polymers and slurries. Our full piston design avoids product build-up and clogging in the valve. Strahman offers a full range of Piston Diverter valves specially designed for this purpose. With Strahman's modular component (MCD) system valves be customized to match with any piping layout.

The valves are available with a wide selection of options including materials of construction, actuators, and customized or standard connections to piping. Other options include rotating pistons for smooth flow, high viscosity flow control and additional drain, injection or vent valves.

Typical applications: Flow management of slurry type and molten polymer processes.

Additional valves for Vent, Drain & Injection applications

For process reasons it can be advantageous to have additional valves installed on the main diverter valve. These valves are typically used to vent or drain process lines or to inject additives. Some examples are shown below:

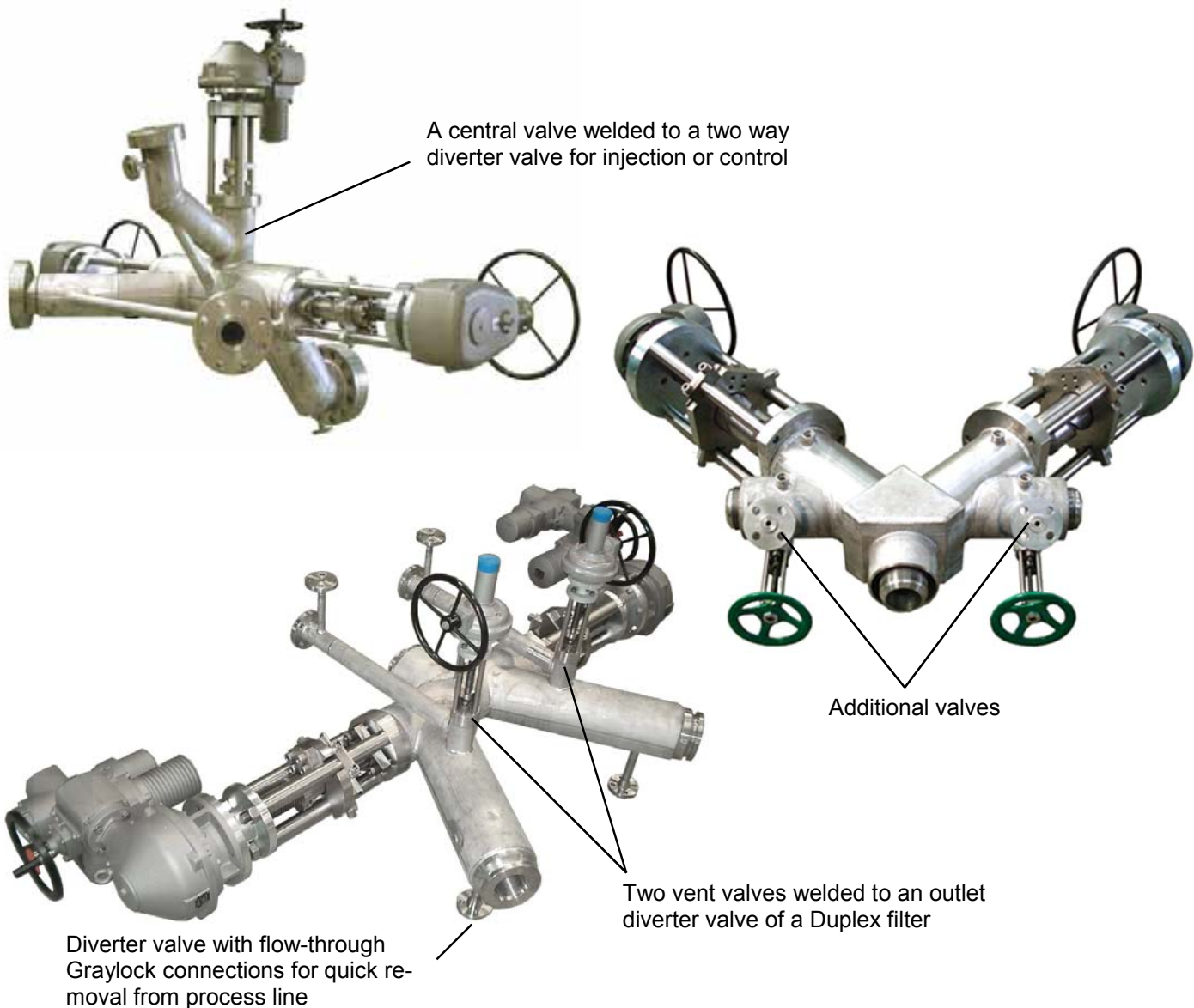

DIVERTER VALVES FOR DUPLEX FILTERS

Strahman diverter valves provide a smooth changeover from one polymer filter to another.

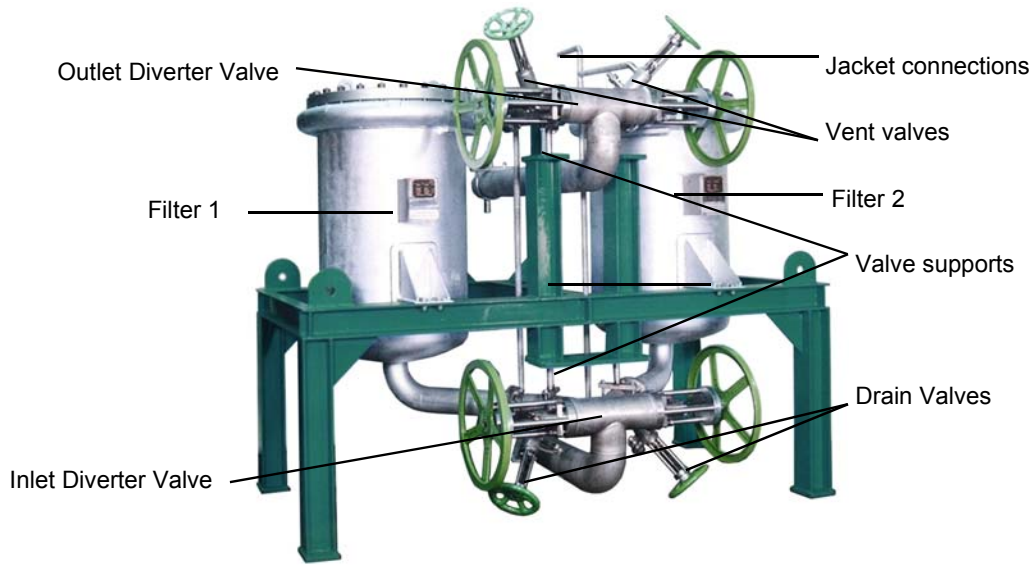

RANGE DEFINITION

| Manufacturing Range | PN 10 | PN 16 | PN 20-150 lbs. | PN 25 | PN 40 | PN 50 300 lbs. | PN64 400 lbs. | PN 100 600 lbs. | PN 150/160-900 lb | PN 250 -1500 lb | PN 320 | PN 420-2500 lb | PN 630 -4500 lb |
|---------------------|-------|-------|----------------|-------|-------|----------------|---------------|-----------------|-------------------|-----------------|--------|----------------|-----------------|
| 3/8"- DIN10 | | | | | | | | | | | | | |
| 1/2"- DIN15 | | | | | | | | | | | | | |
| 3/4"- DIN20 | | | | | | | | | | | | | |
| 1"- DIN25 | | | | | | | | | | | | | |
| 1 1/4"- DIN32 | | | | | | | | | | | | | |
| 1 1/2"- DIN40 | | | | | | | | | | | | | |
| 2"- DIN50 | | | | | | | | | | | | | |
| 2 1/2"- DIN65 | | | | | | | | | | | | | |
| 3"- DIN80 | | | | | | | | | | | | | |
| 4"- DIN100 | | | | | | | | | | | | | |
| 5"- DIN125 | | | | | | | | | | | | | |
| 6"- DIN150 | | | | | | | | | | | | | |
| 8"- DIN200 | | | | | | | | | | | | | |
| 10"- DIN250 | | | | | | | | | | | | | |
| 12"- DIN300 | | | | | | | | | | | | | |
| 14"- DIN350 | | | | | | | | | | | | | |
| 16"- DIN400 | | | | | | | | | | | | | |
| 18"- DIN450 | | | | | | | | | | | | | |
| 20"- DIN500 | | | | | | | | | | | | | |
| 24"- DIN600 | | | | | | | | | | | | | |
| 28"- DIN700 | | | | | | | | | | | | | |
| 32"- DN800 | | | | | | | | | | | | | |
| 36"- DN900 | | | | | | | | | | | | | |
| 40"- DN1000 | | | | | | | | | | | | | |
| 44"-DN1100 | | | | | | | | | | | | | |
| 48"- DN1200 | | | | | | | | | | | | | |

| Manufacturing Range | PN 10 | PN 16 | PN 20-150 lbs. | PN 25 | PN 40 | PN 50 300 lbs. | PN64 400 lbs. | PN 100 600 lbs. | PN 150/160-900 lb | PN 250 -1500 lb | PN 320 | PN 420-2500 lb | PN 630 -4500 lb |
|---------------------|-------|-------|----------------|-------|-------|----------------|---------------|-----------------|-------------------|-----------------|--------|----------------|-----------------|
| 3/8"- DIN10 | | | | | | | | | | | | | |
| 1/2"- DIN15 | | | | | | | | | | | | | |
| 3/4"- DIN20 | | | | | | | | | | | | | |
| 1"- DIN25 | | | | | | | | | | | | | |
| 1 1/4"- DIN32 | | | | | | | | | | | | | |
| 1 1/2"- DIN40 | | | | | | | | | | | | | |
| 2"- DIN50 | | | | | | | | | | | | | |
| 2 1/2"- DIN65 | | | | | | | | | | | | | |
| 3"- DIN80 | | | | | | | | | | | | | |
| 4"- DIN100 | | | | | | | | | | | | | |
| 5"- DIN125 | | | | | | | | | | | | | |
| 6"- DIN150 | | | | | | | | | | | | | |
| 8"- DIN200 | | | | | | | | | | | | | |
| 10"- DIN250 | | | | | | | | | | | | | |
| 12"- DIN300 | | | | | | | | | | | | | |
| 14"- DIN350 | | | | | | | | | | | | | |
| 16"- DIN400 | | | | | | | | | | | | | |
| 18"- DIN450 | | | | | | | | | | | | | |
| 20"- DIN500 | | | | | | | | | | | | | |
| 24"- DIN600 | | | | | | | | | | | | | |
| 28"- DIN700 | | | | | | | | | | | | | |
| 32"- DN800 | | | | | | | | | | | | | |
| 36"- DN900 | | | | | | | | | | | | | |
| 40"- DN1000 | | | | | | | | | | | | | |
| 44"- DN1100 | | | | | | | | | | | | | |
| 48"- DN1200 | | | | | | | | | | | | | |

Inlet Range

Valve Range
M Seal & Dual Seal

M Seal
Only

2-WAY PISTON DIVERTER VALVES

Straight Design

Code: **DPS2**

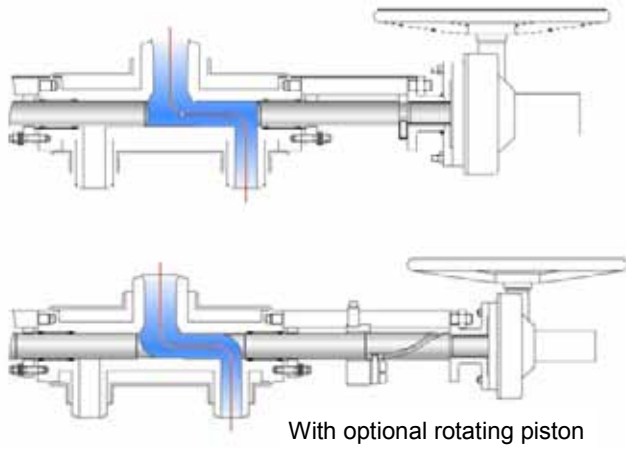

Possible body arrangements

S2

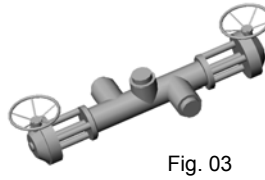
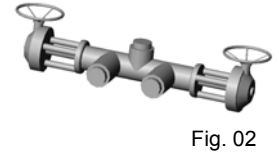
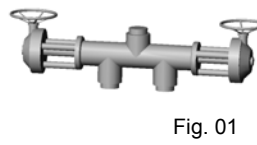

T Design

Code: **DPT2**

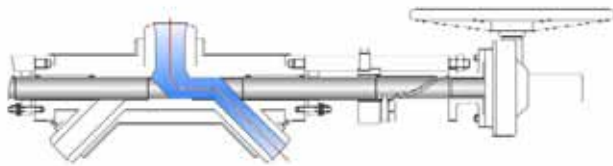

Possible body arrangements

T2

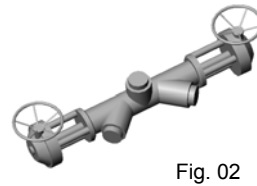
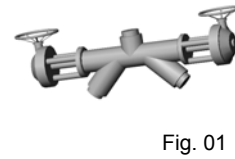

Y Design

Code: **DPY2**

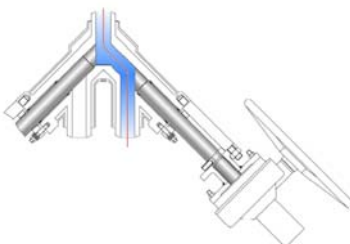
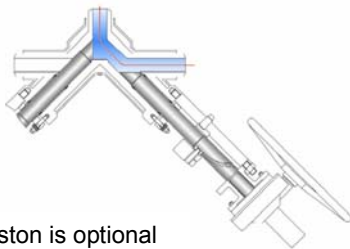

Possible body arrangements

Y2

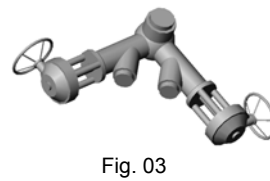
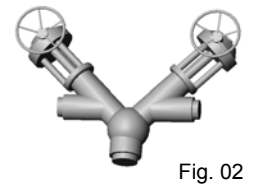
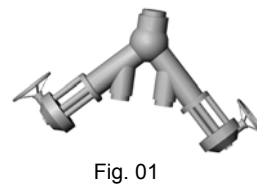

3 WAY PISTON DIVERTER VALVES

Code: **DPS3**

Straight Design

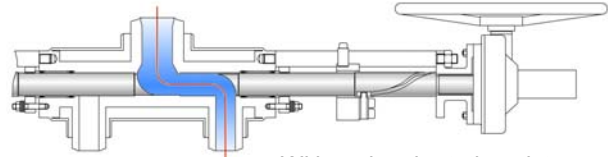
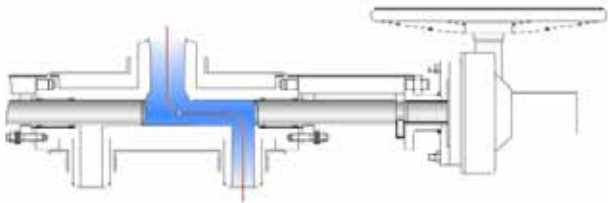

With optional rotating piston

Possible body arrangements

S3

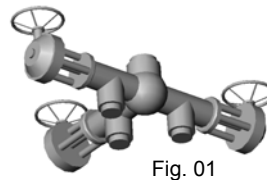

Fig. 01

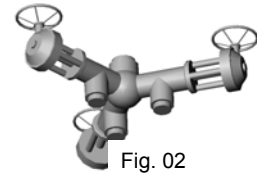

Fig. 02



Fig. 03

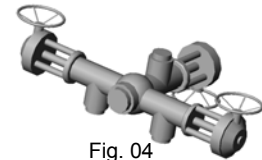
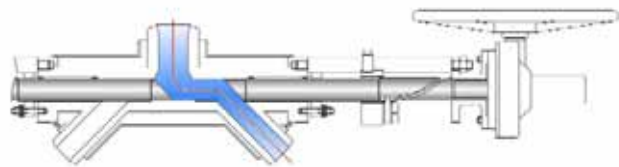

Fig. 04

Code: **DPT3**

T Design



Rotating piston is optional

Possible body arrangements

T3

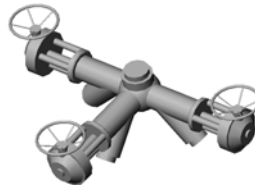

Fig. 01

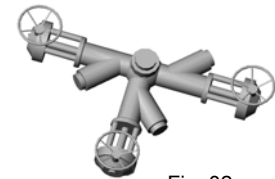

Fig. 02

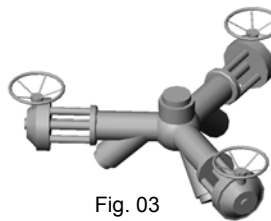
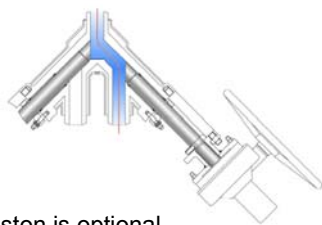

Fig. 03

Code: **DPY3**

Y Design



Rotating Piston is optional



Standard

Possible body arrangements

Y3

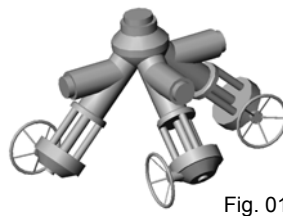

Fig. 01

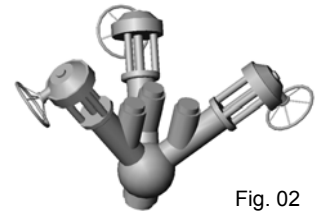

Fig. 02

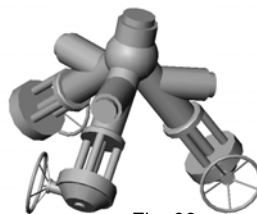

Fig. 03

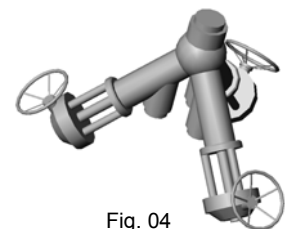
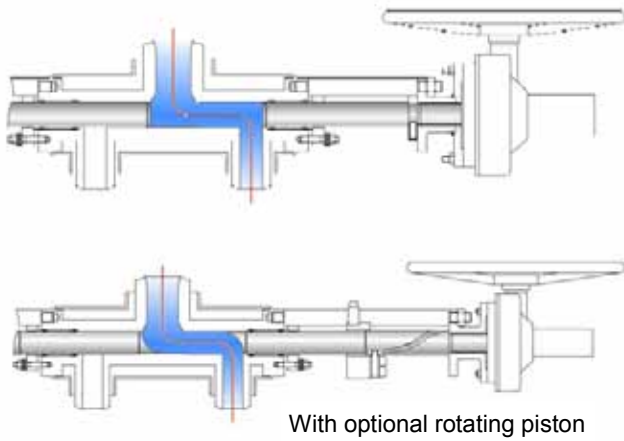

Fig. 04

4-WAY PISTON DIVERTER VALVES

Straight Design

Code: **DPS4**



Possible body arrangements

S4

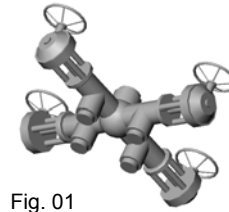

Fig. 01

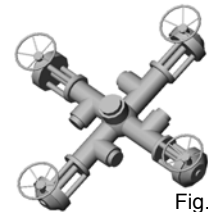

Fig. 02



Fig. 03

T Design

Code: **DPT4**

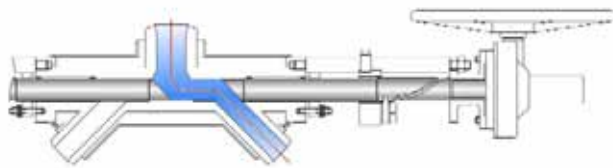

Possible body arrangements

T4

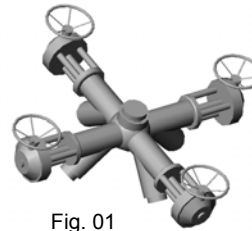

Fig. 01

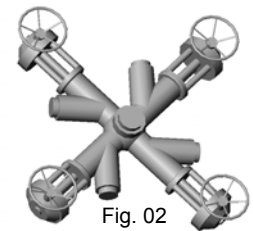
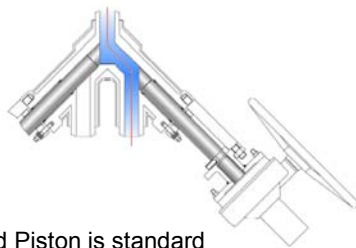

Fig. 02

Y Design

Code: **DPY4**



Contoured Piston is standard

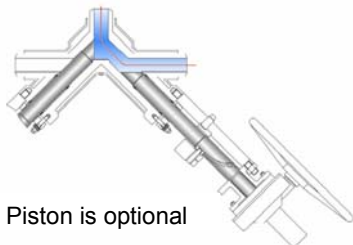

Rotating Piston is optional

Possible body arrangements

Y4

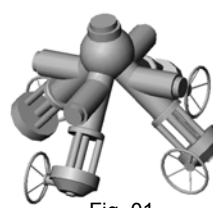

Fig. 01

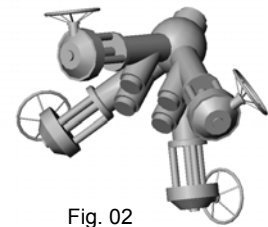
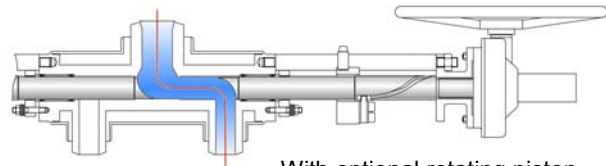
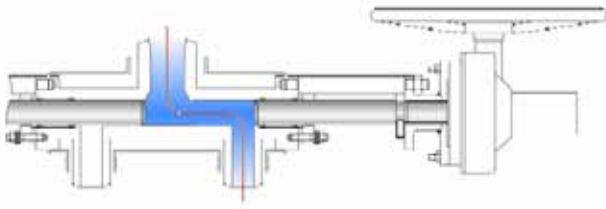

Fig. 02

5-6-WAY PISTON DIVERTER VALVES

Code: **DPS5-DPS6**

Straight Design



With optional rotating piston

Possible body arrangements

S5

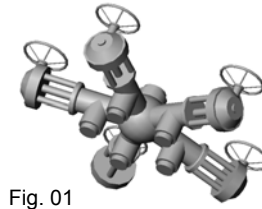

Fig. 01

S6



Fig. 02

Code **DPT5-DPT6**

T Design

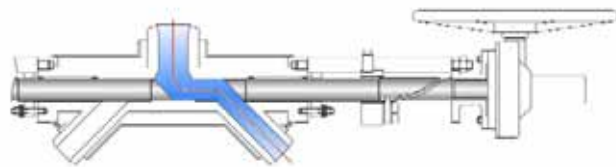

Rotating piston is optional

Possible body arrangements

T5

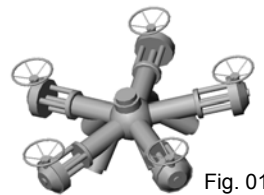

Fig. 01



Fig. 02

T6

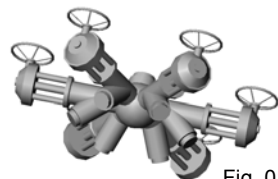
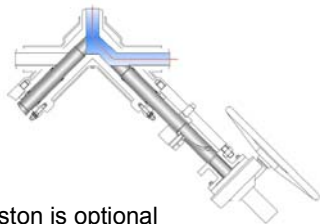

Fig. 01

Code: **DPY5-DPY6**

Y Design



Rotating Piston is optional

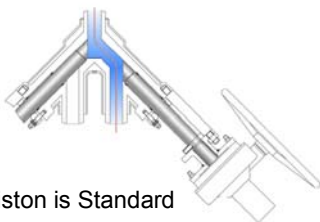

Contoured Piston is Standard

Possible body arrangements

Y5

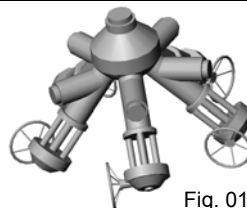

Fig. 01

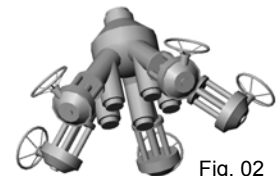

Fig. 02

Y6

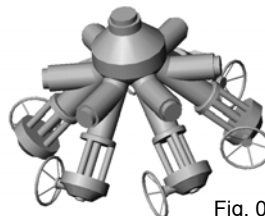

Fig. 01



Fig. 02

SEALING SYSTEMS PISTON VALVES

M Seal- This sealing system offers a wide range of material combinations selected to create a differential hardness between body and plunger seat. The maintenance friendly design of the **M Seal** system provides long & reliable valve performance and is suitable for almost all process conditions.

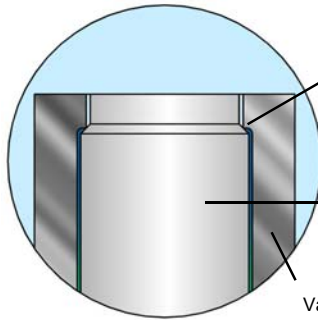

Greater hardness on body seat assures that wear occurs on piston first
Easy maintenance is key

One piece piston design minimizes dead areas

Valve Body

Temperature

Min: -200° C / -330° F
Max: 815° C / 1500° F

Pressure

Max: 630 bar / 9000 psig

M-Control- The **M-Control** system provides customized flow characteristics to regulate a specific laminar flow with high viscosity. The system uses a piston with a specific shape to control flow and/or pressure. **M-Control** uses the specific sealing features of the **M seal** system.

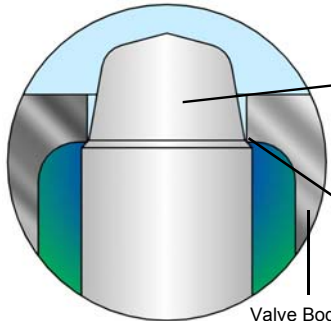

Strahman's experience with high viscosity control valves combined with our calculation software provides a smooth and high performing control valve

Greater hardness on body seat assures that wear occurs on piston first

Valve Body

Temperature

Min: -200° C / -330° F
Max: 815° C / 1500° F

Pressure

Max: 630 bar / 9000 psig

Dual Seal- The **Dual Seal** is a unique double sealing system that works like a piston operating within a cylindrical seat. Unlike other designs, the secondary resilient seal ring is mounted on the piston and will expand after metal to metal contact of the primary seat ring. The design provides a true metal to metal seal in case of resilient seat failure.

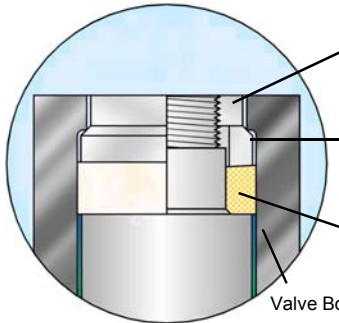

Locking nut is secured by a tack weld

The primary metal to metal seal ring compresses the secondary resilient seal ring

A secondary seal ring is made of resilient material like PTFE, PTFE glass filled

Valve Body

Temperature

Min: -50° C / -60° F
Max: 200° C / 450° F

Pressure

Max: 250 bar / 3550 psig & full vacuum

M Ring Seal- The **M Ring Seal** is also based on a differential hardness between the body and the piston surface. The replaceable metallic seal ring made of aluminum, nickel or titanium provides excellent sealing performance especially in applications that combine full vacuum and temperatures above 200° C.

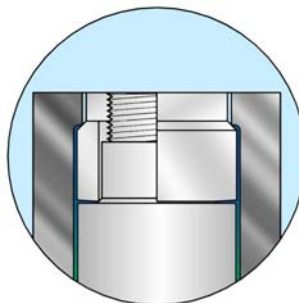

Locking nut is secured by a tack weld

Resilient metal ring seals between the body seat and disc and provides high performance sealing for vacuum and high temperature

Valve Body

Temperature

Min: -200° C / -330° F
Max: 450° C / 840° F

Pressure

Max: 250 bar / 3550 psig & full vacuum

PACKING DEFINITION

Typical Packing Materials:

- PTFE
- PTFE / Aramide Braid
- Carbon / Graphite Braid
- Graphite Braid
- PTFE / Aramide Braid + Graphite
- Lamellar + Expanded Graphite
- Pure Graphite

Live loaded packing arrangement minimizes maintenance

Back seat arrangement is standard on this valve

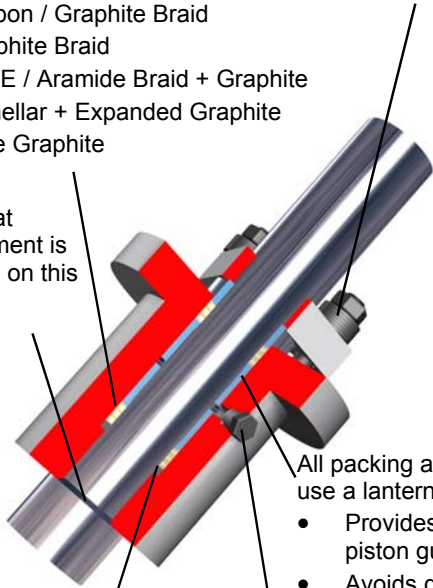

All packing arrangements use a lantern ring that:

- Provides better stem piston guiding
- Avoids dead space in body cavities

Bottom ring material is selected with a differential hardness from the piston to prevent piston damage

Optional 1/4 inch NPTF can be used for leak detection or inert gas injection to avoid leakage to atmosphere by creating an over pressure

VACUUM HOOD

For valves on full vacuum service Strahman offers a special **vacuum package** that maintains tightness to atmosphere. Valves with this package are usually equipped with an **M Ring Seal** design as process sealing. The system uses a replaceable aluminium or nickel seal ring and provides high vacuum performance. This special **vacuum package** provides zero leakage between atmosphere and process.

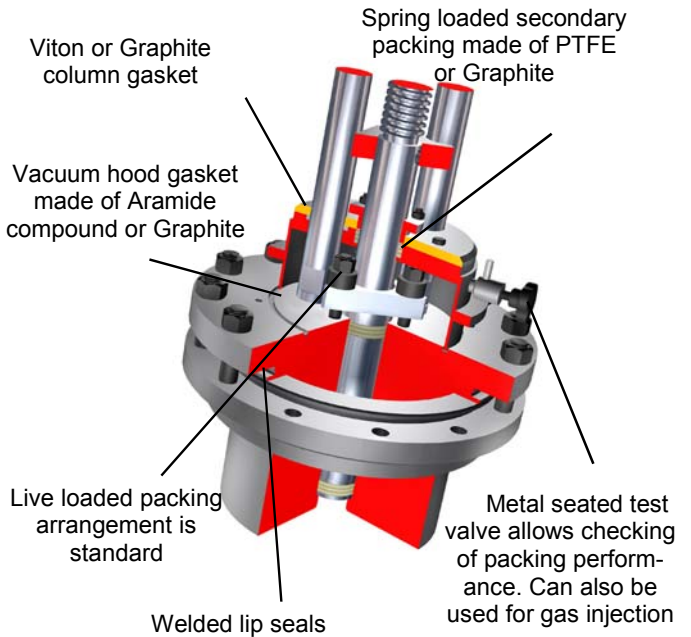

STANDARD BODY GASKET RANGE

- PTFE
- Aramide / Nitrile
- Carbon / Aramide
- Laminated Graphite
- Laminated Graphite / 316
- Spiral Wound 316L / PTFE
- Spiral Wound 316L / Graphite
- Spiral Wound 321 / Graphite
- Spiral Wound Inconel / Graphite
- Spiral Wound Titanium / Graphite
- Welded Lips

JACKET CONNECTIONS

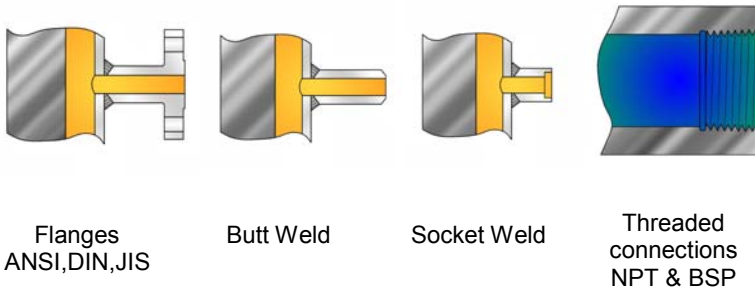

Valve Coding System

| | D | P | S | 2 | M | J |
|---|---|---|---|---|---|---|
| D Diverter Valve | | | | | | |
| P Piston D Disc A Accessories | | | | | | |
| S Straight T T Design Y Y Design \$ Special | | | | | | |
| 2 2 Valves 3 3 Valves 4 4 Valves 6 6 Valves \$ Special | | | | | | |
| M M Seal C M Control D Dual Seal R M Ring Seal | | | | | | |
| J Jacketed - Non-Jacketed | | | | | | |

TECHNICAL & GENERAL INFORMATION

Design Code & Construction

- Design standard compliant with ASME B16.34
- International standards include ANSI, DIN, JIS, API etc.
- Wide range of material selections including carbon steel / stainless steel / Titanium / Hastelloy / Duplex / Monel / Tantalum / Zirconium
- Fabricated, cast, forged and bar stock designs
- Combinations of fabricated, sand and investment casings, and bar stock available

Surface Finish

- For polymer applications, Strahman recommends a surface facing of 300 (Ra 0.4) for all parts are in contact with the medium

Quality assurance & testing

- ISO 9001 compliant
- TUV / HPO / TA Luft
- PED / ATEX / CE marking
- Standard testing procedures

LINE & BRANCH CONNECTIONS



Flanges
ANSI, DIN, JIS



Heated
Flanges

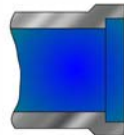

Socket
Weld

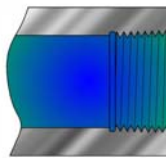

Threaded
connections
NPT & BSP



Butt
Weld

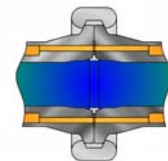

Fast Bolting Union
Graylock Securamax

ACTUATION OPTIONS



Hand Wheel



Bevel Gear



Electric Actuator



Air Motor



Double or single
acting Air Cylinder



Double or single acting Air
Cylinder with Safety Hand Wheel

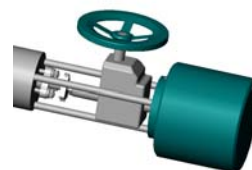

Double or single acting Air
Cylinder with side mounted
Safety Hand Wheel



Hydraulic
Cylinder

The Strahman family of products include:

SAMPLING VALVES

Strahman has a full line of sampling valves that produce live samples without exception. Our sampling valves unique design prevent failure caused by sediment or clogging.

DRAIN VALVES

Strahman Drain Valves are designed to prevent clogging. They are ideal for use in liquid and gas service or with slurries, polymers, and high viscosity fluids that tend to solidify at room temperature.

WASH DOWN EQUIPMENT

Strahman offers a full line of mixing units, hose stations, hoses, nozzles and wash down accessories. Our wash down line is designed for industrial use and is used in a wide variety of industries including food, beverage, pharmaceutical, chemical and other applications.

LINE BLINDS

Strahman Line Blinds provide zero leakage down stream and total isolation on process pipelines, vessels, and maritime applications. No pipeline movement is required when blind position is changed.

Please contact your local Strahman representative for further details
or
visit our website : www.strahmanvalves.com



Corporate Headquarters:

Strahman Valves, Inc. 2801 Baglyos Circle, Bethlehem, PA 18020
Tel: 484. 893.5080 • Fax: 484.893.5099

Strahman France:

Savoie Hexapole, F-73420, Mery, France
Tel: + 33 4 79 35 78 00 • Fax: + 33 4 79 35 78 20

Strahman German Office

Kirchstrasse 16, D-77855, Achern, Germany
Tel: +49 7841 6846530 • Fax: +49 7841 6846531

Last Updated: July, 2012



ISO 9001
QMI-SAI Global